

We point out the minimum requirement of the foundation in our plans. The condition of the specific local situation (for example: ground under the foundation) does not lie our responsibility. If necessary an architect must be consulted.

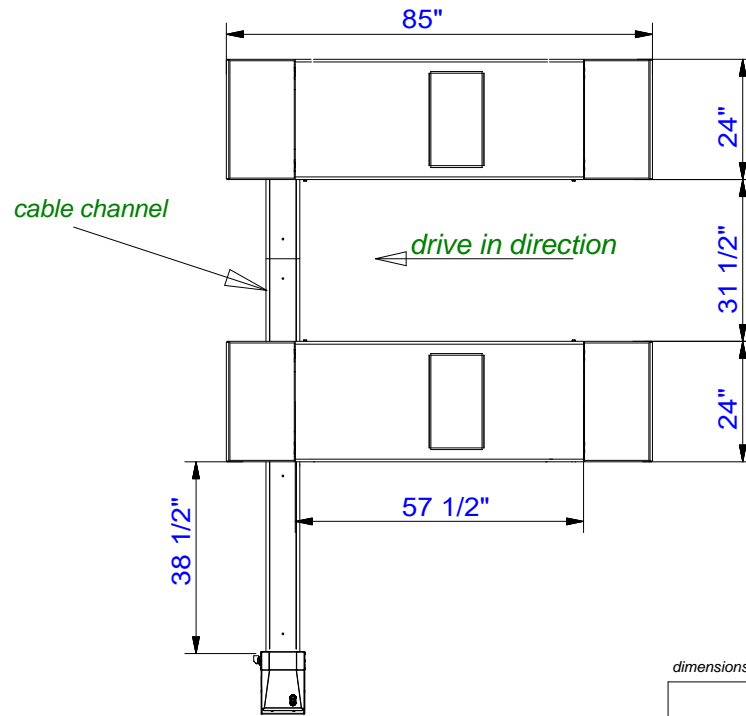
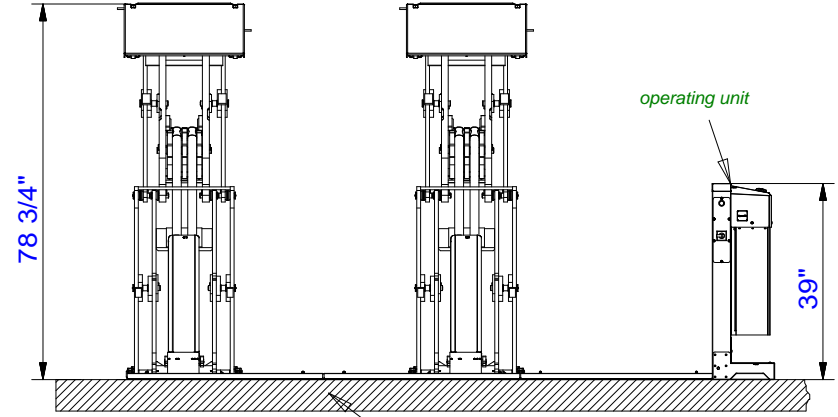
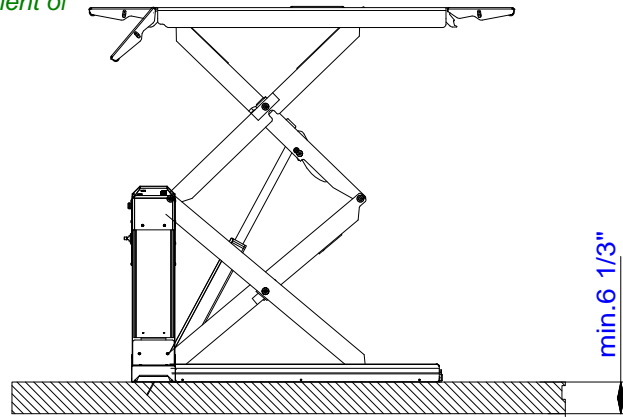

quality of concrete C20/25
normal armoring

Prepared by customer at the operating unit:
power supply: 230V, 60Hz
fuse: 20 Ampere, time lag

capacity: 9000lbs

If ordering, the foundation plan or drawing number must be specified in the order

dimensions and design changes reserved!

(3D CAD-Modell)				Projektionsmethode 1 ISO 5456-2		Benennung / designation		
-	-	-	-	Datum	Name	Jumbo 9 above ground		
-	-	-	-	Bearb.	25.01.2016			MG
-	-	-	-	Gepr.				
-	-	-	-					
b	neues Design	19.10.22	MH	 Korcker Straße 24, 77694 Kehl www.nussbaumlifts.com		Zeichnungsnummer / drawing number		
a	Universalaggr. hinzu	06.07.18	MH			7874_NB_USA		
ind.	Aender. / modification	Datum	Name					